

ferroli

GF N

Cast iron boilers

Solid wood fuel

Heating only



- Heat output 12.3 to 27.5 kW
- Heating body made from nippeded cast iron elements
- Specially shaped elements, good fin distribution and low water capacity ensure excellent heat exchange and low thermal inertia
- Low capacity water grille for excellent boiler efficiency and robust construction
- Combustion chamber designed to hold even large logs
- Readily available, universal accessories

Internal equipment:

- Chain temperature controller
- Overheating safety coil
- Gravity drain safety valve

Packaging: 1 crate

Boiler in wooden crate

Conforms to the Energy Efficiency Directive according to EN 303-5 standard.

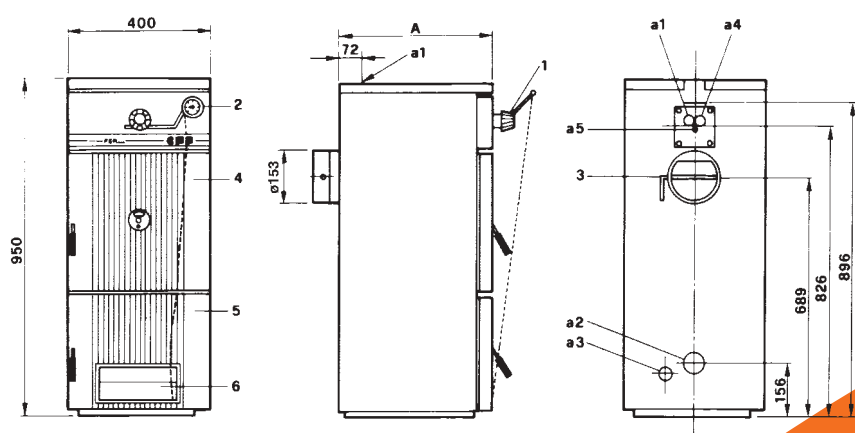

KEY

1. Thermostatic combustion control
2. Temperature gauge
3. Flue draught control
4. Loading door (400x400)
5. Bottom door
6. Air door
- a1. 1.5" water outlet
- a2. 1.5" water return
- a3. Boiler drain
- a4. Safety coil connection
- a5. Safety valve connection

MODELS		GF N 4	GF N 5	GF N 6	GF N 7	GF N 8
Heat output	kW	12.3	16.1	19.9	23.7	27.5
Number of elements in heating body	no.	4	5	6	7	8
Flue diameter	mm	153	153	153	153	153
Boiler water capacity	l	16	20	24	28	32
Boiler depth (A)	mm	447 (A)	547	647	747	847
Maximum operating pressure	bar	3	3	3	3	3
Weight as shipped	kg	130	160	190	220	250